

Experimental verification of the greenhouse effect

3. Communication : Laboratory experiments demonstrating the CO₂ greenhouse effect

Abstract

The third communication is addressed to the general public, in particular to pupils and students. With simple demonstration experiments, the CO₂ greenhouse effect is illustrated by temperature changes, without formulas and mathematical deductions. Its causes but also its limitations are shown. The experiments show that even colder CO₂ can heat the earth-plate under certain conditions by 1.3 ° C. This greenhouse effect is mainly controlled by the temperature of the aerosol-plate, which is representative of clouds or aerosols. The aerosol-plate must be at least 5 ° C colder than the earth-plate in order to achieve a measurable temperature increase. The experiments present an abundance of surprising and partly unknown facets of the greenhouse effect. When there is no external heat, CO₂ causes the earth plate to heat without changing the heat transfer to the aerosol plate or the air temperature. The greenhouse effect is predominantly determined by the natural CO₂ concentrations, with CO₂ showing the greatest effectiveness in the immediate vicinity of the earth-plate. A potentially human-induced increase in atmospheric CO₂ concentrations can therefore only contribute to a small extent to global warming.

1. Introduction

In the first communication (1), a novel apparatus was presented, which can be used flexibly and can experimentally verify different aspects of the greenhouse effect. The first two publications dealt with the interaction of clouds, aerosols and greenhouse gases. It could be proven that there is no independent greenhouse effect at all, but that the effect of greenhouse gases depends on the visible and invisible aerosols of the sky. Using the formulas of Ångström and other researchers, it has been calculated that water vapor (the strongest greenhouse gas) contributes around 30% to the greenhouse effect in clear skies and as little as 5% in clouds (2). These findings are a serious criticism of CO₂ hysteria in Germany and explain why this series of communications is published by EIKE.

The present communication deals with the question whether the increase in temperature of the Earth by CO₂ is experimentally demonstrable and may possibly be used as a demonstration experiment for pupils or students.

On the Internet one can find a whole series of student experiments to demonstrate the greenhouse effect. So why another proposal? No experiment analysed by the author corresponded to the natural conditions of an Earth with an average temperature of 15 ° C and an atmosphere characterized by a temperature gradient. Above all, attempts to demonstrate the greenhouse effect by temperature increase of the CO₂-containing air proved to be a misunderstanding of this effect (3), (4). Also, the measurements were not done against a cold background. Thus, the influence of clouds and aerosols on the greenhouse effect was not recognized. The own conception, which is based on the natural temperatures of the earth and the atmosphere, has led to laboratory experiments that probably make the true, near-Earth CO₂ greenhouse effect visible and comprehensible for the first time. Since this communication applies to the general public, the colloquial term "heat radiation" is equated with infrared (IR) radiation in the following.

In the first communication (1), an apparatus was introduced that mimics the near-Earth atmosphere as a model. Instead of the earth's surface, it contains a so-called earth-plate and, at a large distance, an aerosol-plate, which is representative of a cloud layer of different temperature (height). The most important finding was that the greenhouse effect depends on the temperature of the distant aerosol-plate (2). It could be shown that greenhouse gases and clouds / aerosols are radiation competitors, which hinder each other in the greenhouse effect. These relationships were obtained by gradual cooling of the aerosol plate ("cooling mode").

In order to detect a possible warming of the earth plate after the addition of CO₂, the other surfaces of the apparatus (wall and aerosol plate) should have as constant a temperature as possible during a test. For this task, the "concentration mode" offers, in which only the concentration of CO₂ is varied. In particular, ensure a constant electrical heating of the earth-plate (QE), which is achieved by a special laboratory power supply (Korad KA3005D).

The air temperature between earth- and aerosol-plate is of particular importance in these experiments. The question is whether the fundamental thesis of an alleged "CO₂ greenhouse effect" is a violation of physical laws. According to the ideas of some fundamental sceptics, CO₂ should not be able to contribute to global warming, since the CO₂ of the atmosphere is colder than the earth's surface and heat basically only flows from a warm to a cold body.

To check this thesis, the flexible applicability of the apparatus is of great benefit, since such scenarios can also be simulated. The air temperature inside the tube can be regulated independently of the temperature of the earth-plate by heating of the aluminium tube with water of defined temperature. In this way, an experimental design is realized, which is characterized by three temperature zones. The earth-plate has the highest temperature, followed by the airspace for the potential addition of CO₂, which is 0 - 15 ° C colder, and at the end is located as the coldest pole the aerosol plate, 20 ° C colder than the earth-plate. If the sceptics were right, the earth plate would not heat up if CO₂ was given to an airspace that is colder than the earth plate. For this purpose, two series of experiments were carried out with a 40 ° C or 20 ° C warm earth plate, comparable to a tropical or temperate climate zone of the earth. In both test series, CO₂ was added in 7 to 10 steps (up to a maximum of 55% by volume) to the previously dried and low-CO₂ inside air of the apparatus. After each addition of CO₂, the temperature was read at seven points of the apparatus (Fig. 4) and recorded.

In the first series of experiments (earth plate = 40 ° C) the CO₂ was added at four different airspace temperatures ≤ 40 ° C to determine if the earth plate is also warmed by colder CO₂.

In the second series of experiments (earth plate = 20 ° C), four experiments with different temperatures of the aerosol plate were carried out in order to prove the possible influence of the cloud temperature (in this series CO₂ was added up to a maximum of 12% by volume).

In all eight experiments, the gradual addition of CO₂ resulted in a progressive warming of the earth-plate, even if the CO₂ was significantly colder than the earth-plate (Fig. 1 and 2). The experiments show that CO₂ can in principle, under certain conditions, increase the earth temperature! The mechanism of this so-called greenhouse effect is explained in detail in chapter 2. However, this much may be revealed: The greenhouse effect has nothing to do with a heat flow from cold CO₂ to warm earth.

CO₂ and air have different specific thermal conductivities (Chap. 4, Tab. 1). To exclude that the measured temperature increases of the earth-plate are actually caused by the greenhouse effect and not by changes in the heat conduction, two more experiments with helium and argon were performed instead of CO₂. These inert gases are also characterized by different thermal conductivities to air. Since they are IR inactive, means they do not generate heat radiation, they only influence the heat conduction in the apparatus. A possible falsification of the results of the above eight experiments by heat conduction can be clearly excluded, since in both control tests the temperature of the earth-plate remained unchanged. A detailed description of these experiments can be found in chapter 4.

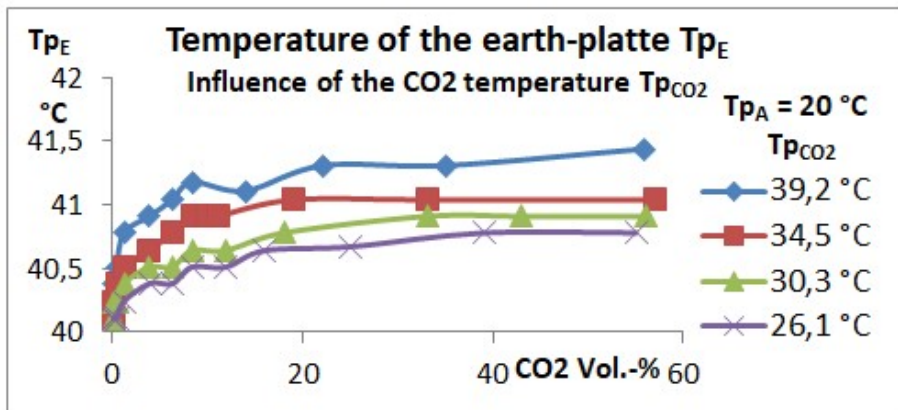

Figure 1: Temperature increase of the 40 °C warm earth-plate after addition of CO2 at different air temperatures T_{pCO2}
 T_{pE} = temperature of the earth-plate, T_{pA} = temperature of the aerosol-plate, T_{pCO2} = temperature of the CO2-containing air

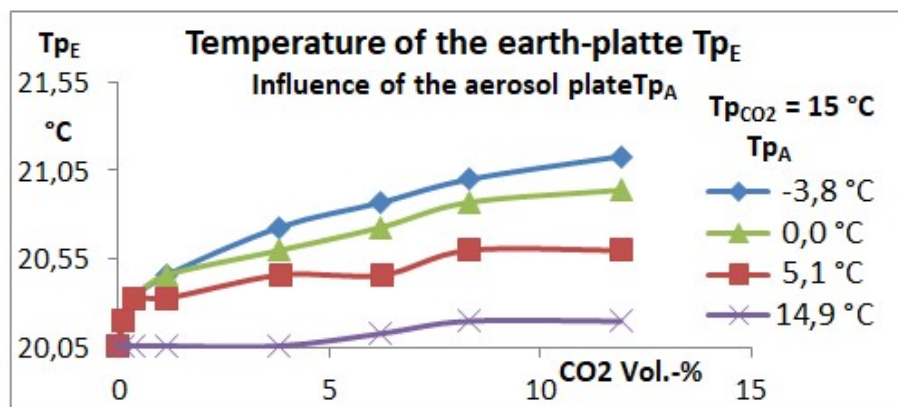

Figure 2: Temperature increase of the 20 °C warm earth-plate after addition of CO2 at different temperatures T_{pA} of the aerosol plate

Both series of experiments (Fig. 1 and 2) show different temperature increases of the earth-plate and allow the following conclusions: Accordingly, the greenhouse effect depends on both the temperature of the CO2-containing air (Fig. 1) as well as the temperature of the aerosol-plate (Fig. 2).

The warmer the CO2 and the colder the aerosol plate the stronger the warming of the earth plate.

The influence of the CO2 temperature (Fig. 1) is reflected in the results of the satellite measurements, which determine the largest greenhouse effect over the equator. Above the South Pole, however, it was found that CO2, due to a temperature inversion, even cools Antarctica, means CO2 has here a negative greenhouse effect (5). A fact little known in the public that explains why there is no global warming in Antarctica. The proven warming of the North Pole is therefore not caused by CO2 but by the soot of the shipping.

Note: Water and ice, according to the law of weight and buoyancy, claim the same volume in any vessel (popular question in school lessons, melting ice does not increase the water level). Thus, the melting of the ice on the North Pole has no influence on the sea level, since this is floating ice.

The actual critique of the official climate hysteria derives from the influence of the aerosol-plate on the greenhouse effect (Fig. 2). The test series shows that the CO2-greenhouse effect is controlled significantly by the temperature of the aerosol-plate (which stands for clouds/aerosols)! The temperature increase of the earth-plate (greenhouse effect) can even completely disappear if the temperatures of the aerosol and Earth plate are approaching, as can be seen in Fig. 2 ($T_{pA} = 14.9$ °C). The 20 °C test series simulates temperatures typical of the Earth under low-lying clouds. This experiment once again shows the dependence of the greenhouse effect on the temperature of the clouds and aerosols (1), (2).

2. The mechanism of the near-earth CO₂ greenhouse effect

It cannot be said that the greenhouse effect is easy to understand. Even the bitter dispute of acknowledged scientists shows that this is a complex subject with many twists and influences.

The used apparatus of about 1 m length imitates only the first approximately 3000 m of the atmosphere. It is assumed that there is a closed cloud cover at this altitude. At an altitude of 3 km, the air is on average 18 ° C colder than the earth's surface (0.6 ° C / 100 m), after which the temperature of the aerosol plate was selected. With regard to the amount of CO₂, however, the imitated layer thickness of the atmosphere is much smaller and depends on the concentration of added CO₂. The imitated layer thickness of an atmosphere containing 400 ppm of CO₂ is obtained by dividing the CO₂ test concentration (in % by volume) by 0.04. At a concentration of 12%, therefore, 300 m and at 55% 1375 m of an atmosphere with 400 ppm of CO₂ are reproduced.

Reflections on the heat fluxes in the greenhouse effect refer to the energy transport exclusively through heat radiation. The greenhouse effect is therefore treated as an idealized, closed system. Influencing the greenhouse effect by other energy flows of the atmosphere would in principle be feasible with the apparatus, but was not a planned objective of the present investigations.

In the mentioned section of the atmosphere, in addition to heat radiation, energy is also transported through the water cycle and through air movements. These heat flows influence the temperature of these air layers and thus also the CO₂ greenhouse effect. A simple student experiment is overwhelmed by these complications. Also, the relativization of CO₂ radiation by the water vapor radiation cannot be investigated because of the high boiling point of water.

To understand the greenhouse effect, one must first make it clear that each (solid and liquid) body of our natural environment (also the aerosols of the atmosphere) constantly emits heat rays, an invisible light. As with an incandescent lamp, energy is required. In contrast to the incandescent bulb, however, an external energy source is not absolutely necessary. The energy for the heat radiation can also be taken from the internal energy of the body, from the kinetic and potential energy of its atoms or molecules, its internal oscillations and rotations. In this case, the body would have to cool down by constant consumption of energy. This usually does not happen, however, since the body also receives heat radiation from its surroundings, so that (after some time) all the bodies in a closed room have the same temperature (law according to Kirchhoff).

We cannot see this exchange of heat radiation, as this infrared light (IR radiation) is invisible to our eyes. The lack of perception of this radiation is probably the reason that many people alone have problems with the term "radiation" and are more likely to think of Fukushima or Chernobyl than their natural environment. Heat radiation can be experienced, for example, by approaching a very hot object or using a thermal imaging camera. According to the equation of Stefan and Boltzmann, the size of this radiation (radiation density = energy per area) is calculated on the basis of the temperature (T high 4 law) for an ideal, so-called "black" body. The warm earth-plate thus generates at 20 ° C a heat radiation of 419 W/m² and at 40 ° C it is 545 W/m². If the earth-plate were isolated in space, far away from other celestial bodies, it would cool down and its temperature would approach the absolute zero (-273.15 ° C) after some time, only by radiative cooling (supply of energy by heat radiation).

In the apparatus, this is different, since the earth-plate is also the recipient of a heat radiation of its environment. This so-called counter-radiation is mainly generated by the aerosol-plate. However, due to the lower temperature of the aerosol-plate, the counter-radiation is smaller than the heat radiation of the earth-plate. The bottom line therefore remains a certain difference of transmitted and received radiation, which defines the heat loss (radiant cooling) of the earth-plate. Exactly this amount of heat loss is delivered in the experiment by the electric heating Q_E , whereby the energy supply and absorption of the earth-plate are equal and their temperature remains constant.

In contrast to solid and liquid bodies, only certain so-called IR-active gases, such as CO₂, can produce a gas radiation (6). The CO₂ radiation is not a thermal radiation (heat radiation) but a line radiation of selected wavelengths. If CO₂ is filled into the apparatus, the gas takes over the temperature of the warm aluminium wall and generates a gaseous radiation that is larger (in the wavelength range of the CO₂ emission bands) than that of the (colder) aerosol-plate.

This increases the counter-radiation, which reduces the radiation cooling of the earth-plate. Radiation cooling and heating of the earth-plate Q_E are no longer in equilibrium if the heating Q_E remains constant. A heat jam occurs, which causes the earth-plate to warm up. Due to the higher temperature, the earth-plate (according to the law of Stefan-Boltzmann) can radiate more heat, which also increases the radiant cooling until ultimately heat loss and heating of the earth-plate are equal again, i.e. the radiant cooling reaches its old value again.

As long as no external energy is involved in the exchange of radiant heat, the heat loss of the earth plate is identical to the heat transport from the earth to the aerosol plate. In other words, the heating Q_E is transmitted unchanged by heat radiation to the aerosol plate. Other conceivable heat fluxes between earth- and aerosol-plate such as convection or diffusion are excluded by the type of construction of the apparatus (1). Thus can be formulated for the "pure" greenhouse effect:

In a closed system, CO₂ causes the earth plate to heat up without changing the heat transfer to the aerosol-plate.

Although CO₂ loses energy through the radiation exchange with the colder aerosol-plate, on the other hand it gains an equal amount of energy from the earth-plate due to its increased heat emission caused by CO₂. In a closed system, absorption and emission of CO₂ molecules are the same. Everything else would be a violation of the law of energy conservation by Julius Robert Mayer. In accordance with this, it was found in the above-mentioned experiments that the air temperature is not changed with a constant heat transport by CO₂. Thus, another theorem can be formulated:

The air temperature does not indicate the greenhouse effect, but changes in the heat transport.

The adaptation of the air temperature to the heat flow is made possible by the greater temperature dependence of the CO₂ emission compared to its absorption. There is experimental evidence for this thesis. For example, if the earth-plate is replaced by a red light lamp, the air temperature increases with the addition of CO₂, because here the heat flux increases and CO₂ requires a higher temperature for an adequate emission (3). Examples of a constant heat flow and constant air temperatures are the experiments presented here, in particular experiment No. 5/3 (Tab. 12, without wall heating). In other experiments to be published soon, the Q_E heating was lowered during a trial to get a constant temperature of the Earth plate. Here even a cooling of the air after the addition of CO₂ was observed.

This realization explains that all previous, alleged attempts of demonstrating the greenhouse effect have investigated the wrong effect. Whether the air temperature changes after the addition of CO₂ depends first and foremost on the process parameters. This explains why air warming occurred in the Al-Gore experiment, but cooling was found in a review by Anthony Watts.

Al Gore had not given any detailed information on the experimental conditions, so Watts had to rely only on assumptions. Depending on the experimental conditions, Watts found either no warming or even a cool down (4).

3. The heat transport influenced by CO₂

In the above experiments, the heat transfer is registered in the apparatus of Peltier elements. The Peltier elements are firmly connected to the aerosol plate. They measure both heat radiation and heat conduction, which act on the aerosol plate.

With the addition of CO₂ in the area of small CO₂ concentrations, there was a strong increase in heat transport, to stagnate at high concentrations (Fig. 3). Is by that the thesis of a constant heat transport refuted? No, this rule applies only to very small CO₂ concentrations (as in the atmosphere) and to closed systems (without external energy impact). These are conditions that were not met in the above experiments, since high CO₂ concentrations have to be used to simulate an atmosphere of around 1500 m. The wall heaters also unintentional supplied energy, so there was no closed system.

Peltier elements generate a voltage in the millivolts area if their topside is warmer than their underside. Since their undersides are firmly connected to the cold aerosol-plate, the Peltier elements (in series connected) already show the heat transfer within the "empty" apparatus by a voltage of up to 100 mV before the addition of CO₂. If this initial value is set equal to zero, the influence of CO₂ on the heat transport can be recognized by the changed voltages of the Peltier elements dU_A . In the following, for simplicity, the heat transport is equated with the voltage change dU_A .

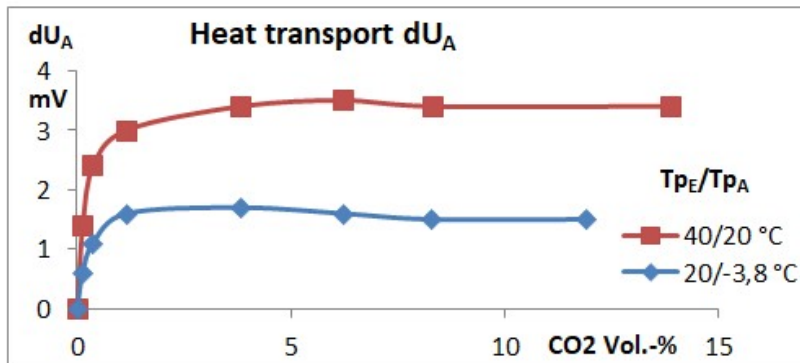

Figure 3: Increase in the heat transport in the trial Nos. 8/3 and 34/3

The heat flux of the cold aerosol-plate to the adjacent warm air (in the range of T_{p_4}) is also influenced by the thermal conductivity of the air-CO₂ mixtures. Since CO₂ has a smaller specific thermal conductivity than air (Tab. 1), the heat conductivity of the CO₂-containing air decreases after each addition of CO₂, which would also have to reduce the dU_A values. The actual increase of the dU_A values could be caused only by CO₂ emissions. The dU_A values would be even greater if the influence of the CO₂ heat conduction would be considered.

The CO₂ gas radiation has a logarithmic dependence on the CO₂ concentration. However, the heat conduction for CO₂-air mixes decreases linearly as CO₂ concentrations rise. From a certain CO₂ concentration, the opposite effects achieve the same action, so that the heat transport dU_A stagnates (Fig. 3). These explanations could be confirmed experimentally by adding helium and argon (instead of CO₂) (Chap. 4).

The measurement disturbance caused by the heat conduction can at least partly be circumvented by an experimental trick. For this purpose, the apparatus is filled with argon, which has a similar thermal conductivity as CO₂, before the addition of CO₂. With the addition of CO₂, the heat conduction of the gas phase now changes only slightly, which has a significant influence on the heat transport. The next communication will give an example.

The increase in heat transport means that more heat is transferred to the aerosol plate by CO₂. But where did this extra energy come from? The answer is found in the water-warmed aluminium wall, which provides the CO₂-containing air with additional heat accordingly the following mechanism:

CO₂ radiates more energy in the direction of the aerosol plate than it gets back from this cold plate. So the CO₂-containing air should cool down, which prevents the side wall, however. Due to the well heat-conductive aluminium wall, the internal air heats from the wall heating system. This hidden and variable flux of heat explains the increase of the heat transport dU_A in the eight experiments (Fig. 3, Chap. 5 and Tab. 2 to 9).

This thesis could be proved experimentally by switching off the wall heating units 1 – 3. In order to understand the experiments, one must first familiarise themselves with the constructive details of the apparatus (1). Fig. 4 shows schematically the arrangements of the three wall heaters WH₁ to WH₃ and the location of the temperature measuring points T_{p_0} to T_{p_4} .

The three wall heaters can be independently supplied with water of defined temperature. "WH = nil" means that no wall heating was switched on and "WH1-3" that all three heating areas were connected with the 40 ° C warm thermostats (Fig. 5).

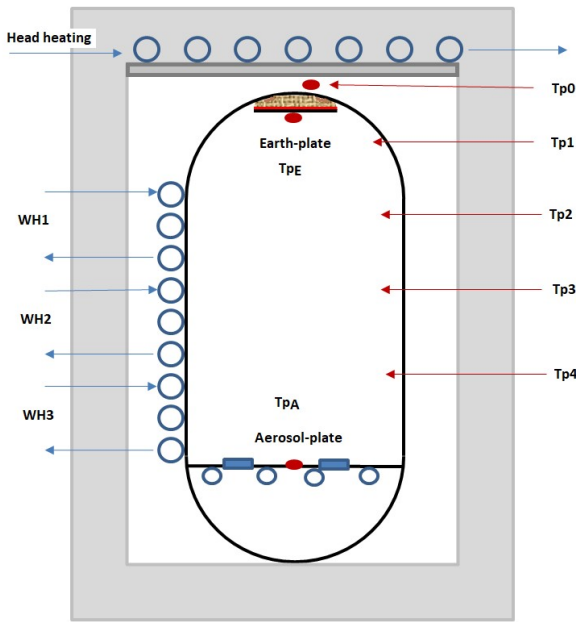

Figure 4: Schematic representation of the measuring points T_{pE} , T_{pA} , T_{p0} to T_{p4} , the head heating and the wall heating WH1 to WH3

Fig. 5 (left image) shows the starting temperatures of the measuring points T_{p0} to T_{p4} . The figure shows how the air temperatures are affected by the wall heaters. An almost identical temperature of all measuring points T_{p0} to T_{p4} can be achieved when all three segments are heated (blue line). The gradual shutdown of the wall heating systems (starting with WH₃) leads to a cooling down in the corresponding heating areas.

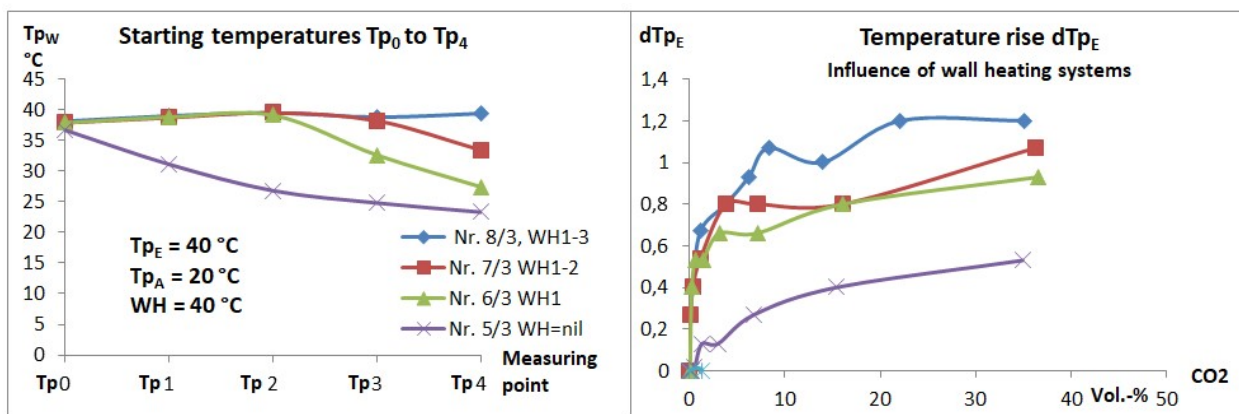

Figure 5: Influence of the wall heaters on the air temperatures ($T_{p0} - T_{p4}$) and temperature rise of the earth-plate dT_{pE}

Experiment 5/3 without wall heating (WH=nil) refutes the widespread view that CO₂ leads to a warming of the air. Neither the average temperature of the air (\varnothing from T_{p0} to T_{p4}) nor the temperature at the point T_{p4} showed a significant change in temperature after addition of CO₂ (Fig. 6, left image and Chap. 5.3, Tab. 12).

Since the CO₂ radiation also depends on the CO₂ temperature (Chap. 1, Fig. 1), the gradual shutdown of the wall heating systems also reduces the CO₂ greenhouse effect (the heating of the earth-plate). The last shutdown (WH=nil), however, causes a significantly larger temperature jump (violet line) than the first shutdowns (Fig. 5, right picture).

This is a very important observation that shows that the CO₂-greenhouse effect has a very short range. The CO₂ greenhouse effect depends not only on the CO₂ temperature and concentration, but also on the distance to the earth plate. The CO₂, which is located near the earth-plate, has the largest share of its warming.

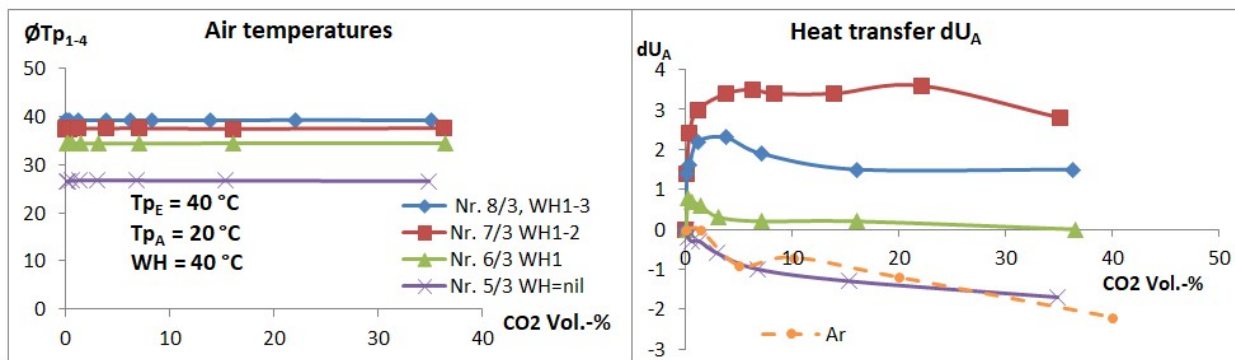

Figure 6: Constant air temperatures ($\varnothing Tp_{1-4}$) and changes in heat transport dU_A depending on the wall heating system

Each further shutdown of a heating area reduced the heat transport dU_A and tended to lead to the expected constant heat transport (Fig. 6, right picture).

Of particular importance is the experiment 5/3 "WH=nil" (without wall heating), which is very close to a closed system. Here the heat transport shows a slightly negative gradient (Fig. 6, violet line). A control experiment with Argon instead of CO2 (Chap. 5.4.2.) has an almost identical negative trend (Fig. 6, yellow line). Since Argon does not produce heat radiation, but only influences the heat conduction, it is hereby demonstrated that the negative gradient is caused exclusively by heat conduction and not by heat radiation.

If the heat conduction changed by CO2 is taken into account, the experiment could be regarded as proof of a constant heat transfer in the CO2 greenhouse effect. This hypothesis holds a huge explosiveness, because since the weather observations by satellites it is claimed that CO2 reduces the heat radiation into the universe! (6). If this thesis could be clearly refuted, the IPCC would have major problems in equating "global warming" with CO2.

Here, however, the experiment in its present embodiment meets the limits of experimental evidence. Although there can be no doubt about a constant heat transfer in a closed system, it is fair to say that the experiment is not unambiguously. For one, only temperatures of the near-earth atmosphere are investigated and on the other hand the earth-plate has a smaller diameter than the aluminium tube (with its greenhouse gases). This reduces the radiation density of the heat radiation of the earth-plate at its propagation towards the aerosol plate. As a result, the CO2 through its larger radiation surface can cause an increase in the heat transfer to the aerosol plate even though CO2 was slightly colder than the earth plate. However, these are also happy circumstances, because otherwise a CO2-induced increase in the heat transport would not have been seen at all.

The smaller earth-plate was a consequence of the then largest commercially available heating foil. If the experiments are professionally repeated, an equally sized soil and aerosol plate would be advisable to clarify the heat transport in question. The greenhouse effect is not affected by the unequal plate sizes, since this is about irradiation and not radiation of the earth plate.

The experiments with the presented apparatus are therefore only proposed as demonstration experiments. This allows the aforementioned phenomena and correlations of the CO2-greenhouse effect to show to pupils and students and to expose one or another CO2 myth as error. Moreover, it can be demonstrated that there is no independent CO2-greenhouse effect at all, because too many other factors relativize the effect of CO2.

4. The influence of helium and argon on the heat conduction

It should be determined whether the results of the CO2 greenhouse effect were influenced by the CO2 thermal conductivity. As in the Chap. 1 indicated, the IR-inactive gases Helium and Argon were added to the "empty" apparatus. These noble gases cannot generate heat radiation, but are characterized by very different specific thermal conductivity compared to air (Tab. 1).

Table 1: Specific thermal conductivity of some gases

Gas	$10^{-3} \cdot W / (m \cdot K)$
Helium	156,7
Methane	30,2
Air	24,4
Argon	16,3
Propane	15,1
CO ₂	14,2
Butane	13,4
CH ₂ Cl ₂	9,2

The earth plate had a temperature of 25 ° C in these experiments. The aerosol-plate has been cooled down to -10 ° C to allow the highest possible heat flow through heat conduction. The WH₁₋₂ wall heaters were supplied with 25 ° C warm water from a thermostat. WH₃ was not used to detect the influence of the inert gases on the air temperature and heat transfer in the measuring range of Tp₄.

The inert gases had no influence on the temperature of the earth-plate Tp_E (Fig. 7, left image). This has shown that the temperature rise dTp_E after the addition of CO₂ were caused exclusively by the greenhouse effect and not by heat conduction!

The temperature constancy of the earth-plate is a typical feature of the experimental apparatus. The earth-plate is in a kind of heat bell, formed by the head heating and the wall heating WH₁, which creates an environment of similar temperatures. The different specific thermal conductivity of the test gases is not noticeable here, since ultimately the physical heat flux (heat conduction) is also dependent on the temperature difference of the Earth plate and its immediate environment, which is very small here.

However, the inert gases had a large influence on the heat transfer to the aerosol-plate, as can be seen in the voltage change dU_A of the Peltier elements (Fig. 7, right picture). As in chapter 3 explained, these sensors register not only the heat radiation but also the heat conduction. It should be noted that the aerosol-plate is much colder than the adjacent aluminium wall. Due to the large temperature difference there is a strong heat flux from the warm wall (in the range of Tp₄) to the cold aerosol-plate, which is influenced by the inert gases.

Since Argon (just like CO₂) is a worse heat conductor than air, when Argon is added, less heat is transferred to the Peltier elements, which causes these elements to produce a lower voltage. In Fig. 7 this "Argon effect" is shown by a negative, almost linear decrease in the heat transport dU_A (right image, green line). Theoretically, this would require a slight increase in the temperature Tp₄ after addition of Argon (left image, green line), which was not indicated by the thermometers. The low accuracy of the thermometer for the wall temperature of ± 0.1 ° C is the cause for this.

The difference of the specific thermal conductivity to air is much greater in Helium than in Argon. As a result, the change of heat conduction is much stronger when adding Helium instead of Argon. Helium has additionally a reverse effect. The addition of helium increases the heat conduction of the air, which increases the heat transport dU_A (Fig. 7, red line). So much heat is extracted from the non-heated area (Tp₄) that there is even a temperature drop from 19.0 to 18.2 ° C with the addition of helium. This decrease in temperature is the reason why the dU_A heat transport in helium is not linear and even decreases with high helium concentrations.

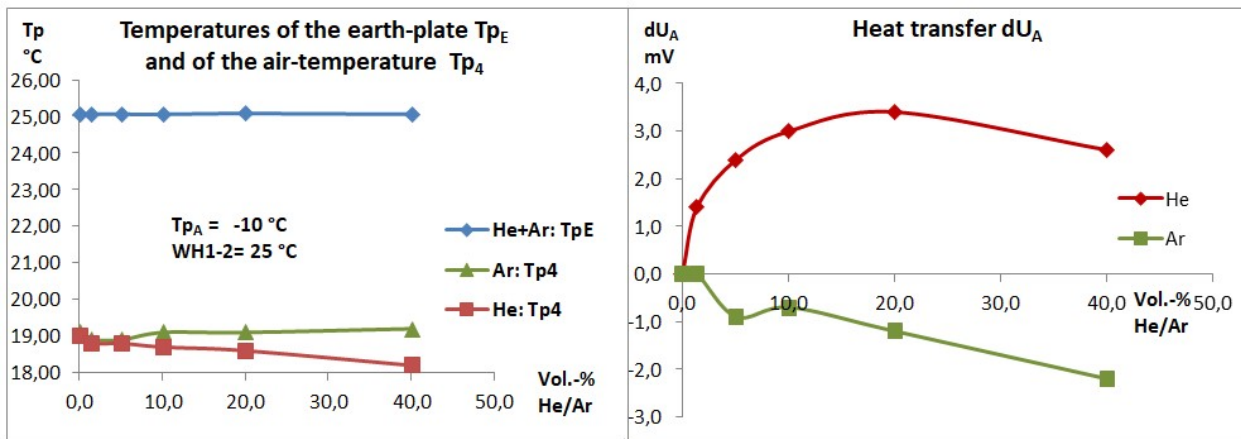

Figure 7: Temperature and heat transport changes due to Helium and Argon.

4. Appendix- Experimental data

The outer parts of the apparatus (heat insulation, head heating and cooling unit) were changed several times in the course of the experimental verification of the greenhouse effect. By April 2018, a total of 495 experiments had been carried out. That may be exaggerated, but new ways need their time. An extensive data supply seemed necessary to build trust that the very small greenhouse effects were real and were sufficiently accurate and reproducible determined.

The experiments presented in this report are mainly from the year 2015. During this time, the hoses for the head heating were, unlike in (1), on a polystyrene plate above the dome (Fig. 4).

In order to be able to study the influence of CO₂, before beginning an experiment, the greenhouse gases water vapor and CO₂ from the interior of the apparatus must be almost completely removed in order to obtain a defined initial value. For this purpose, the indoor air of the apparatus is guided with an air pump for aquariums up to 24 hours over solid sodium hydroxide until a CO₂ concentration is reached \ll 100 ppm. The heating Q_E of the earth plate is varied until the desired temperature of this plate is reached. After that, the voltage for a constant heating Q_E was only slightly changed (the resistance of the heating wires depends on the temperature of the earth plate!). The heating power Q_E is calculated from the product of the measured voltage and current, relative to a fictitious earth-plate of 1 m².

The aerosol plate is connected to a glycol/water bath, which is cooled by a cooling unit to the corresponding temperature. An electric heating rod in this bath allows fine adjustment for a constant temperature of the aerosol-plate during an experiment. The heating of the side wall is divided into three equally large segments WH 1 – 3, which can be operated independently of each other with tempered water from a thermostat (Fig. 4). Irrespective of the wall heating, the aluminium tube is still surrounded by a 9.5 cm thick layer of Styrofoam balls as insulation from the test room.

Tp₀ is the surface temperature of the dome measured from the outside, Tp₁ to Tp₄ are the air temperatures in the dome or the aluminium tube at about 25 cm intervals (Fig. 4) or (1).

The temperature changes of the earth-plate dTp_E and the voltage changes of the Peltier elements dU_A are the difference to the first value without CO₂. They characterize the effect of CO₂ and are the most important results of the experiments.

5.1. The influence of the background radiation of the aerosol-plate

Four experiments were carried out at different temperatures (from + 15 to -3.8 ° C) of the aerosol-plate. The voltage for the electric heating of the earth-plate Q_E was varied before CO₂ addition until this plate had a temperature of 20.06 ° C. After that, Q_E was no longer changed and in seven steps the CO₂ concentration was increased to 11.9 vol.-%.

% and all temperatures were registered after each CO₂ addition (tab. 2 to 5). The temperature values for the Earth plate are shown graphically in Fig. 2.

The wall segments WH₁ and WH₂ were supplied by a thermostat with 15.0 °C of warm water. The third segment WH₃, in the measuring range of Tp₄, was not connected to the thermostat to be able to detect possible changes in the CO₂ temperatures without external influence. However, no significant influence on the Tp₄ values was detected after addition of CO₂.

As expected, however, the starting temperature of Tp₄ decreased from 15.5 °C in the individual experiments (Tab. 2) to 12.5 °C (Tab. 5) by their proximity to the aerosol plate and their decreasing temperature Tp_A.

The water temperature of the head heater was 20 °C. After addition of CO₂, Tp₀ showed a similar rise in temperature as the earth-plate, as the dome is also exposed to the increasing radiation of CO₂.

Table 2: Experiment No. 36/3, temperature of the aerosol plate = 15 °C

Tp _E °C	Tp _A °C	Tp ₀ °C	Tp ₁ °C	Tp ₂ °C	Tp ₃ °C	∅ Tp ₁ - Tp ₃	Tp ₄ °C	U _A mV	Q _E W/m ²	CO ₂ Vol.-%	dU _A mV	dTp _E °C
20,06	14,85	20,87	16,2	14,8	14,8	15,3	15,5	4,9	29,3	0,004	0,0	0,00
20,06	14,94	20,87	16,3	15,0	15,0	15,4	15,6	5,3	29,1	0,13	0,4	0,00
20,06	14,94	20,87	16,3	15,0	15,1	15,5	15,6	5,4	29,1	0,37	0,5	0,00
20,06	14,94	20,87	16,4	15,0	15,1	15,5	15,6	5,3	29,3	1,15	0,4	0,00
20,06	14,94	20,87	16,4	15,0	15,1	15,5	15,6	5,4	29,3	3,82	0,5	0,00
20,13	14,94	20,95	16,5	15,0	15,1	15,5	15,7	5,5	29,3	6,23	0,6	0,07
20,20	14,94	21,02	16,5	15,1	15,1	15,6	15,6	5,4	29,3	8,3	0,5	0,14
20,20	14,94	21,12	16,5	15,1	15,2	15,6	15,7	5,0	29,3	11,9	0,1	0,14

Table 3: Experiment No. 32/3, temperature of the aerosol plate = 5 °C

Tp _E °C	Tp _A °C	Tp ₀ °C	Tp ₁ °C	Tp ₂ °C	Tp ₃ °C	∅ Tp ₁ - Tp ₃	Tp ₄ °C	U _A mV	Q _E W/m ²	CO ₂ Vol.-%	dU _A mV	dTp _E °C
20,06	5,06	20,12	15,6	14,8	14,7	15,0	13,6	29,5	70,4	0,001	0,0	0,00
20,20	5,06	20,38	15,8	15,0	14,8	15,2	13,9	30,0	70,4	0,13	0,5	0,14
20,33	5,06	20,38	15,8	15,0	14,9	15,2	13,9	30,2	70,4	0,38	0,7	0,27
20,33	5,06	20,38	15,7	14,8	14,7	15,1	13,8	30,1	70,4	1,16	0,6	0,27
20,46	5,06	20,38	15,7	14,9	14,8	15,1	13,9	30,1	70,4	3,83	0,6	0,40
20,46	5,06	20,38	15,7	14,9	14,8	15,1	13,9	30,1	70,4	6,24	0,6	0,40
20,60	5,06	20,38	15,8	15,0	14,8	15,2	13,9	30,0	70,4	8,31	0,5	0,54
20,60	5,06	20,38	15,8	15,0	14,8	15,2	13,9	30,0	70,4	11,9	0,5	0,54

Table 4: Experiment No. 33/3, temperature of the aerosol plate = 0 °C

Tp _E °C	Tp _A °C	Tp ₀ °C	Tp ₁ °C	Tp ₂ °C	Tp ₃ °C	∅ Tp ₁ - Tp ₃	Tp ₄ °C	U _A mV	Q _E W/m ²	CO ₂ Vol.-%	dU _A mV	dTp _E °C
20,06	-0,03	19,89	15,6	15,0	14,8	15,1	13,1	40,2	94,3	0,002	0,0	0,00
20,20	-0,03	19,89	15,6	15,1	14,9	15,2	13,0	41,4	94,3	0,12	1,2	0,14
20,33	0,1	20,13	15,7	15,1	15,0	15,3	13,1	41,7	94,3	0,37	1,5	0,27
20,46	-0,03	20,13	15,6	15,0	14,8	15,1	13,1	42,3	94,3	1,15	2,1	0,40
20,60	-0,03	20,13	15,6	15,0	14,9	15,2	13,1	42,4	94,3	3,82	2,2	0,54
20,73	-0,03	20,38	15,6	15,0	14,9	15,2	13,1	42,5	94,3	6,23	2,3	0,67
20,87	-0,03	20,38	15,7	15,0	15,0	15,2	13,1	42,5	94,3	8,3	2,3	0,81
20,94	-0,03	20,38	15,7	15,0	15,0	15,2	13,1	42,6	94,3	11,9	2,4	0,88

Table 5: Experiment No. 34/3, temperature of the aerosol plate = - 3.8 ° C

Tp _E °C	Tp _A °C	Tp ₀ °C	Tp ₁ °C	Tp ₂ °C	Tp ₃ °C	∅ Tp ₁ - Tp ₃	Tp ₄ °C	U _A mV	Q _E W/m ²	CO ₂ Vol.-%	dU _A mV	dTp _E °C
20,06	-3,81	20,13	15,4	15,0	14,9	15,1	12,5	49,7	109,8	0,003	0,0	0,00
20,20	-3,81	20,13	15,4	15,0	14,9	15,1	12,5	50,3	109,8	0,13	0,6	0,14
20,33	-3,81	20,13	15,4	15,0	14,8	15,1	12,4	50,8	109,8	0,37	1,1	0,27
20,46	-3,81	20,38	15,5	15,0	14,8	15,1	12,4	51,3	109,8	1,15	1,6	0,40
20,73	-3,81	20,38	15,6	15,0	14,9	15,2	12,4	51,4	109,8	3,82	1,7	0,67
20,87	-3,81	20,38	15,6	15,1	14,9	15,2	12,4	51,3	109,8	6,23	1,6	0,81
21,00	-3,81	20,58	15,6	15,1	14,9	15,2	12,4	51,2	109,8	8,31	1,5	0,94
21,13	-3,81	20,63	15,6	15,0	15,0	15,2	12,5	51,2	109,8	11,9	1,5	1,07

5.2. The influence of the CO₂ temperature

All three wall segments WH₁ to WH₃ were supplied by the same thermostat with warm water. Four Tests were carried out at different thermostat temperature (from 20 to 40 ° C). The temperature measuring points Tp₂ to TP₄ are controlled by these wall heaters and show approximately the same values. The measuring point Tp₁ is located in the dome and shows a mixing temperature of the dome and wall heating. The CO₂ temperature is defined as an average of Tp₁ to Tp₄. In the measuring range Tp₁ a slight temperature rise is recorded at high CO₂ concentrations caused by the rising temperatures of earth plate and dome. The average temperatures from Tp₁ to TP₄ showed no significant change in the increase in CO₂ concentration.

The voltage for the electric heating of the earth-plate Q_E was varied before CO₂ addition until this plate had a temperature of 40.11 ° C. After that, Q_E was no longer changed and in 11 steps the CO₂ concentration increased to around 55 Vol.-% and registered all temperatures after each CO₂ addition (Tab. 6 to 9). The temperatures of the earth-plate are shown graphically in Fig. 1. A graphic representation of the heat transport can be found in Fig. 3.

Table 6: Experiment No. 11/3, wall heating WH_{1..3} = 25 ° C, CO₂ temperature (∅ Tp₁-Tp₄) = 26.1 ° C

Tp _E °C	Tp _A °C	Tp ₀ °C	Tp ₁ °C	Tp ₂ °C	Tp ₃ °C	Tp ₄ °C	∅ Tp ₁ - Tp ₄	U _A mV	Q _E W/m ²	CO ₂ Vol.-%	dU _A mV	dTp _E °C
40,11	20,02	37,40	29,1	25,1	24,8	25,0	26,0	36,1	132,3	0,0095	0,0	0,00
40,11	20,02	37,40	29,1	25,2	24,9	25,0	26,1	35,9	132,3	0,14	-0,2	0,00
40,11	20,02	37,40	29,1	25,3	24,9	25,0	26,1	35,6	132,3	0,38	-0,5	0,00
40,24	20,02	37,40	29,2	25,3	24,9	25,1	26,1	35,6	132,3	1,16	-0,5	0,13
40,38	20,02	37,40	29,1	25,3	24,9	25,1	26,1	34,8	132,3	3,86	-1,3	0,27
40,38	20,02	37,40	29,1	25,3	24,9	25,0	26,1	34,7	132,3	6,26	-1,4	0,27
40,51	20,02	37,64	29,2	25,3	25,0	25,0	26,1	34,6	132,3	8,33	-1,5	0,40
40,51	20,02	37,40	29,2	25,3	24,9	25,1	26,1	34,4	132,3	11,9	-1,7	0,40
40,64	20,02	37,89	29,3	25,3	24,9	25,0	26,1	34,6	132,7	16,0	-1,5	0,53
40,67	20,02	37,64	29,3	25,3	24,9	25,1	26,2	34,4	132,3	25,0	-1,7	0,56
40,78	20,02	37,64	29,2	25,1	24,9	25,0	26,1	34,3	132,3	39,0	-1,8	0,67
40,78	20,02	37,64	29,3	25,2	24,9	25,0	26,1	33,6	132,3	55,0	-2,5	0,67

Table 7: Experiment No. 10/3, wall heating WH_{1..3} = 30 ° C, CO₂ temperature (∅ Tp₁-Tp₄) = 30.3 ° C

Tp _E °C	Tp _A °C	Tp ₀ °C	Tp ₁ °C	Tp ₂ °C	Tp ₃ °C	Tp ₄ °C	∅ Tp ₁ - Tp ₄	U _A mV	Q _E W/m ²	CO ₂ Vol.-%	dU _A mV	dTp _E °C
40,11	20,02	37,64	32,2	29,8	29,4	29,6	30,3	46,6	120,5	0,0037	0,0	0,00
40,24	20,02	37,64	32,2	29,9	29,5	29,6	30,3	46,8	120,1	0,14	0,2	0,13
40,24	20,02	37,64	32,2	29,9	29,5	29,6	30,3	47,0	120,1	0,38	0,4	0,13
40,38	20,02	37,64	32,3	29,9	29,5	29,6	30,3	46,9	120,1	1,16	0,3	0,27
40,51	20,02	37,64	32,2	29,9	29,4	29,6	30,3	46,8	120,1	3,83	0,2	0,40
40,51	20,02	37,64	32,3	29,9	29,4	29,6	30,3	46,6	120,1	6,24	0,0	0,40
40,64	20,02	37,64	32,3	29,9	29,5	29,6	30,3	46,5	120,1	8,31	-0,1	0,53
40,64	20,02	37,64	32,3	29,9	29,4	29,6	30,3	46,3	120,1	11,9	-0,3	0,53
40,78	20,02	37,89	32,3	29,9	29,5	29,6	30,3	46,6	120,1	18,0	0,0	0,67
40,91	20,02	37,89	32,4	29,8	29,4	29,6	30,3	46,1	120,1	33,0	-0,5	0,80
40,91	20,02	37,89	32,4	30,0	29,5	29,7	30,4	46,1	120,1	43,0	-0,5	0,80
40,91	20,02	37,89	32,3	29,9	29,5	29,6	30,3	45,7	120,1	56,0	-0,9	0,80

Table 8: Experiment No. 9/3, wall heating $WH_{1-3} = 35^\circ\text{C}$, CO2 temperature ($\emptyset Tp_1-Tp_4$) = 34.5°C

T_{pE} °C	T_{pA} °C	T_{p0} °C	T_{p1} °C	T_{p2} °C	T_{p3} °C	T_{p4} °C	$\emptyset T_{p1}-T_{p4}$	U_A mV	Q_E W/m ²	CO2 Vol.-%	dU_A mV	dT_{pE} °C
40,11	20,17	37,76	35,3	34,4	33,8	34,3	34,5	57,9	108,9	0,001	0,0	0,00
40,24	20,17	37,89	35,3	34,5	33,8	34,3	34,5	58,8	108,9	0,13	0,9	0,13
40,38	20,16	37,89	35,3	34,4	33,8	34,2	34,4	59,0	108,9	0,38	1,1	0,27
40,51	20,17	37,89	35,3	34,5	33,9	34,3	34,5	59,2	108,9	1,16	1,3	0,40
40,64	20,17	37,89	35,3	34,4	33,8	34,2	34,4	59,1	108,9	3,83	1,2	0,53
40,78	20,17	37,89	35,4	34,5	33,8	34,3	34,5	59,1	108,9	6,24	1,2	0,67
40,91	20,17	37,89	35,4	34,4	33,8	34,2	34,5	58,9	108,9	8,31	1,0	0,80
40,91	20,17	37,89	35,5	34,5	33,9	34,2	34,5	58,9	108,9	10,0	1,0	0,80
40,91	20,17	38,14	35,4	34,5	33,9	34,3	34,5	59,4	108,9	11,0	1,5	0,80
41,04	20,17	38,14	35,6	34,5	33,9	34,4	34,6	59,4	108,9	19,0	1,5	0,93
41,04	20,17	38,14	35,5	34,5	33,9	34,2	34,5	59,2	108,9	33,0	1,3	0,93
41,04	20,17	37,89	35,5	34,5	33,9	34,2	34,5	58,5	108,9	57,0	0,6	0,93

Table 9: Experiment No. 8/3, wall heating $WH_{1-3} = 40^\circ\text{C}$, CO2 temperature ($\emptyset Tp_1-Tp_4$) = 39.2°C

T_{pE} °C	T_{pA} °C	T_{p0} °C	T_{p1} °C	T_{p2} °C	T_{p3} °C	T_{p4} °C	$\emptyset T_{p1}-T_{p4}$	U_A mV	Q_E W/m ²	CO2 Vol.-%	dU_A mV	dT_{pE} °C
40,11	20,17	38,14	39,0	39,5	38,8	39,4	39,2	71,6	93,9	0,003	0,0	0,00
40,38	20,17	38,14	39,0	39,7	38,8	39,4	39,2	73,0	93,9	0,14	1,4	0,27
40,51	20,17	38,14	39,1	39,6	38,8	39,4	39,2	74,0	93,9	0,38	2,4	0,40
40,78	20,17	38,14	39,1	39,7	38,8	39,4	39,3	74,6	93,9	1,16	3,0	0,67
40,91	20,17	38,14	39,1	39,6	38,8	39,3	39,2	75,0	93,9	3,83	3,4	0,80
41,04	20,17	38,38	39,1	39,6	38,8	39,3	39,2	75,1	93,9	6,24	3,5	0,93
41,18	20,17	38,38	39,2	39,6	38,8	39,3	39,2	75,0	93,9	8,31	3,4	1,07
41,11	20,17	38,38	39,1	39,6	38,8	39,4	39,2	75,0	93,9	13,9	3,4	1,00
41,31	20,17	38,38	39,2	39,7	38,8	39,4	39,3	75,2	93,9	22,1	3,6	1,20
41,31	20,17	38,38	39,2	39,6	38,8	39,4	39,3	74,4	93,9	35,1	2,8	1,20
41,44	20,17	38,38	39,2	39,6	38,8	39,4	39,3	74,2	93,9	55,9	2,6	1,33

5.3. The influence of wall heating

The control experiment is a repetition of experiment 8/3 (Tab. 9), but the wall heaters were turned off one after another. Depending on the number of heating zones, different temperatures develop in the tube.

Table 10: Experiment # 7/3, $WH_{1+2} = 40^\circ\text{C}$; Temperature gradient: $T_{p1} = 38.9$, $T_{p2} = 39.5$, $T_{p3} = 38.2$, $T_{p4} = 33.4^\circ\text{C}$ (\emptyset)

T_{pE} °C	T_{pA} °C	T_{p0} °C	T_{p1} °C	T_{p2} °C	T_{p3} °C	T_{p4} °C	$\emptyset T_{p1}-T_{p4}$	U_A mV	Q_E W/m ²	CO2 Vol.-%	dU_A mV	dT_{pE} °C
39,84	20,07	37,89	38,7	39,5	38,2	33,4	37,5	52,0	93,5	0,003	0,0	0,00
40,11	20,17	37,89	38,8	39,5	38,2	33,5	37,5	53,4	93,5	0,13	1,4	0,27
40,24	20,17	37,89	38,8	39,4	38,1	33,3	37,4	53,6	93,5	0,38	1,6	0,40
40,38	20,17	37,89	39,0	39,5	38,2	33,4	37,5	54,2	93,5	1,16	2,2	0,54
40,64	20,17	38,14	39,0	39,5	38,2	33,4	37,5	54,3	93,5	3,83	2,3	0,80
40,64	20,17	38,14	39,1	39,5	38,2	33,4	37,6	53,9	93,9	7,10	1,9	0,80
40,64	20,17	37,97	38,9	39,4	38,1	33,4	37,5	53,5	93,9	16,10	1,5	0,80
40,91	20,17	38,14	39,1	39,5	38,3	33,5	37,6	53,5	93,9	36,3	1,5	1,07

Table 11: Experiment No. 6/3, $WH_1 = 40^\circ \text{C}$; Temperature gradient: $T_{p_1} = 38.8$, $T_{p_2} = 39.0$, $T_{p_3} = 32.5$, $T_{p_4} = 27.4^\circ \text{C}$ (\emptyset)

T_{p_E} °C	T_{p_A} °C	T_{p_0} °C	T_{p_1} °C	T_{p_2} °C	T_{p_3} °C	T_{p_4} °C	$\emptyset T_{p_1}$ - T_{p_4}	U_A mV	Q_E W/m ²	CO ₂ Vol.-%	dU_A mV	dT_{p_E} °C
40,38	20,02	37,89	38,8	39,1	32,6	27,4	34,5	44,9	105,2	0,06	0,0	0,00
40,78	20,02	37,89	38,8	39,0	32,5	27,4	34,4	45,7	105,2	0,26	0,8	0,40
40,91	20,02	37,89	38,8	39,0	32,5	27,4	34,4	45,6	105,2	0,61	0,7	0,53
40,91	20,02	37,89	38,8	39,0	32,6	27,4	34,5	45,5	105,2	1,38	0,6	0,53
41,04	20,02	37,89	38,8	39,0	32,5	27,3	34,4	45,2	105,2	3,14	0,3	0,66
41,04	20,02	37,89	38,7	38,9	32,5	27,4	34,4	45,1	105,2	7,10	0,2	0,66
41,18	20,02	37,89	38,8	39,0	32,6	27,4	34,5	45,1	105,2	16,10	0,2	0,80
41,31	20,02	37,89	38,8	39,0	32,6	27,5	34,5	44,9	105,2	36,5	0,0	0,93

Table 12: Experiment No. 5/3, without wall heating; Temperature gradient: $T_{p_1} = 31.2$, $T_{p_2} = 27.0$, $T_{p_3} = 25.0$, $T_{p_4} = 23.4^\circ \text{C}$ (\emptyset)

T_{p_E} °C	T_{p_A} °C	T_{p_0} °C	T_{p_1} °C	T_{p_2} °C	T_{p_3} °C	T_{p_4} °C	$\emptyset T_{p_1}$ - T_{p_4}	U_A mV	Q_E W/m ²	CO ₂ Vol.-%	dU_A mV	dT_{p_E} °C
40,38	20,02	36,69	31,1	26,8	24,8	23,3	26,5	33,3	134,7	0,07	0,0	0,00
40,38	20,02	36,66	31,1	26,9	24,8	23,4	26,6	33,1	134,7	0,24	-0,2	0,00
40,40	20,03	36,66	31,2	27,0	25,0	23,5	26,7	33,0	134,7	0,58	-0,3	0,02
40,51	20,02	36,66	31,2	27,0	25,1	23,5	26,7	33,0	134,7	1,32	-0,3	0,13
40,51	20,02	36,66	31,2	27,1	25,1	23,5	26,7	32,7	134,7	3,00	-0,6	0,13
40,65	20,02	36,41	31,2	27,0	25,1	23,5	26,7	32,3	134,7	6,80	-1,0	0,27
40,78	20,02	36,68	31,2	27,0	25,0	23,5	26,7	32,0	134,7	15,40	-1,3	0,40
40,91	20,02	36,90	31,2	26,9	24,9	23,4	26,6	31,6	134,7	34,9	-1,7	0,53

5.4. The influence of heat conduction

The wall segments WH_1 and WH_2 and the head heating were supplied by a thermostat with 25.0°C of warm water. The third segment WH_3 , in the measuring range of T_{p_4} , was not connected to the thermostat to be able to detect possible changes by adding the inert gases.

The voltage for the electric heating of the earth-plate Q_E was varied before addition of the inert gases until this plate had a temperature of 25.06°C . After that Q_E was no longer changed and in 5 steps the concentration of the inert gases was increased up to 40 Vol.-% and all temperatures were registered after each concentration increase. The changes in the heat transport dU_A are shown graphically in Fig. 7.

5.4.1. The influence of Helium

Helium has an extremely high specific thermal conductivity of $156.7 \text{ W}/(\text{m} \cdot \text{K})$. Due to the increasing thermal conduction after addition of Helium, the heat transport dU_A also increases strongly and even leads to a cooling at the measuring point T_{p_4} from the beginning 19.0 to 18.2°C . However, Helium does not affect the temperature of the earth-plate ($dT_{p_E} = 0$).

Table 13: Experiment 19/6: Influence of helium on the temperature of the earth plate T_{p_E} and the heat transfer dU_A .

T_{p_E} °C	T_{p_A} °C	T_{p_0} °C	T_{p_1} °C	T_{p_2} °C	T_{p_3} °C	$\emptyset T_{p_1}$ - T_{p_3}	T_{p_4} °C	U_A mV	Q_E W/m ²	He Vol.-%	dU_A mV	dT_{p_E} °C
25,06	-10,15	25,03	24,6	25,1	25,1	24,9	19,0	101,6	125,43	0,0	0,0	0,00
25,06	-10,15	25,2	24,6	25,1	25,0	24,9	18,8	101,7	125,43	1,4	1,4	0,00
25,06	-10,14	25,03	24,7	25,1	25,1	25,0	18,8	102,8	125,43	5,0	2,4	0,00
25,06	-10,15	25,03	24,6	25,1	25,1	24,9	18,7	103,0	125,43	10,1	3,0	0,00
25,08	-10,15	25,03	24,7	25,1	25,1	25,0	18,6	104,0	125,43	20,0	3,4	0,02
25,06	-10,15	25,03	24,7	25,2	25,3	25,1	18,2	104,2	124,04	40,1	2,6	0,00

5.4.2. The influence of Argon

Argon with $0.0163 \text{ W / (m} \cdot \text{K)}$, similar to CO_2 (0.0142), has a lower specific thermal conductivity than air (0.0244). Due to the decreasing heat conduction after addition of argon, the heat transport dU_A is also reduced. The heat conduction of gas mixtures is a linear function of their composition. This dependence could even be detected in the case of Argon, since in this case the temperature of the measuring point T_{p_4} hardly changed. The temperature of the earth-plate is not affected by Argon ($dT_{p_E} = 0$).

Table 14: Experiment 21/6: Influence of Argon on the Temperature of the Earth Plate T_{p_E} and the Heat Transport dU_A .

T_{p_E} °C	T_{p_A} °C	T_{p_0} °C	T_{p_1} °C	T_{p_2} °C	T_{p_3} °C	$\varnothing T_{p_1-}$ T_{p_3}	T_{p_4} °C	U_A mV	Q_E W/m^2	Ar Vol.-%	dU_A mV	dT_{p_E} °C
25,06	-10,15	25,29	24,7	25,0	25,0	24,9	19,1	102,1	124,48	0,0	0,0	0,00
25,06	-10,15	25,29	24,7	25,1	25,0	24,9	18,9	102,1	124,48	1,4	0,0	0,00
25,06	-10,15	25,29	24,6	25,0	25,0	24,9	18,9	101,2	124,48	5,0	-0,9	0,00
25,06	-10,15	25,29	24,7	25,1	25,0	24,9	19,1	101,4	124,48	10,1	-0,7	0,00
25,06	-10,15	25,29	24,7	25,1	25,0	24,9	19,1	100,9	124,94	20,0	-1,2	0,00
25,06	-10,15	25,29	24,7	25,1	25,1	25,0	19,2	99,9	125,4	40,1	-2,2	0,00

Bibliography

1. **Schnell, Michael.** Experimentelle Verifikation des Treibhauseffektes Teil 1: Die gegenseitige Beeinflussung von Wolken und Treibhausgasen. [Online] 25. März 2018. <https://www.eike-klima-energie.eu/2018/03/25/experimentelle-verifikation-des-treibhauseffektes-teil-1-die-gegenseitige-beeinflussung-von-wolken-und-treibhausgasen/>.
2. —. 2.Mitteilung: Die Hintergrundstrahlung der Wolken und Aerosole. [Online] <https://www.eike-klima-energie.eu/2018/06/03/experimentelle-verifikation-des-treibhauseffektes/>.
3. **Stephan Sirtl.** Absorption thermischer Strahlung durch atmosphärische Gase. [Online] 12. 11 2010. [Zitat vom: 15. 01 2018.] http://hpfr03.physik.uni-freiburg.de/arbeiten/diplomarbeiten/sirtl_staatsexamen_2010.pdf.
4. **Anthony Watts.** Anthony Watts Thrashes Al Gore's Climate Change Experiment. [Online] 20. 11 2011. [Zitat vom: 12. 01 2018.] <https://shortlittlerebel.com/2011/10/20/anthony-watts-thrashes-al-gores-climate-change/>.
5. *Naturwissenschaftliche Anmerkungen zu Argumenten der Treibhausdiskussion.* **Volz, Hans.** 9, s.l. : Erdöl-Erdgas-Kohle, 2015, Bd. 116.
6. Gasstrahlung. [Online] 2018. Juni 2018. <https://de.wikipedia.org/wiki/Gasstrahlung>.